

# FRB

## FLATWORK FOLDER

A highly programmable folder offering one, two or four feeding lanes and the ability to automatically perform two to three primary folds and up to three cross folds, the FRB delivers high-quality, automated folding of small and large items alike. Using air-jet technology, the FRB offers an advanced touch-screen control, multi-program operation, and quality components for consistent, quality folding.

The thickness of the article is automatically taken into account during the first cross fold. A retractable pneumatic roller works in conjunction with a mechanical blade to automatically adjust the opening distance for item thickness — ensuring precise folding.



### FOLDING CONFIGURATIONS

#### 2/3 CROSS FOLDS ON ONE LANE

- This concept maximizes fold quality by adapting to any type of linen. Working in 2 or 4 lanes, the exit is on the table.

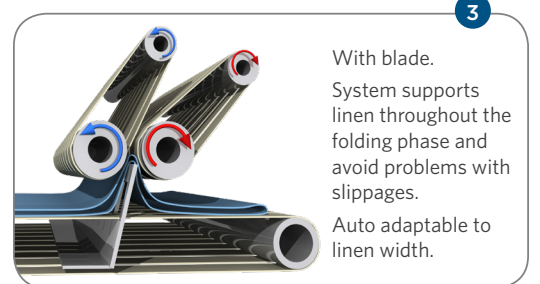
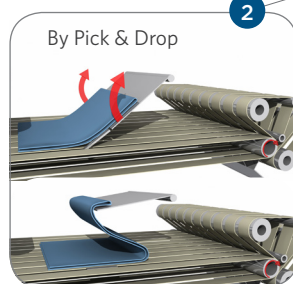
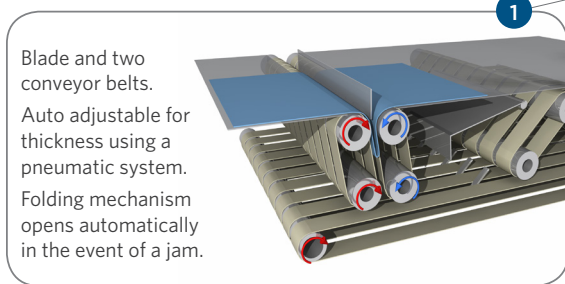

#### PRIMARY FOLDING

- Two primary folds as standard and a third primary fold (optional) for large items.

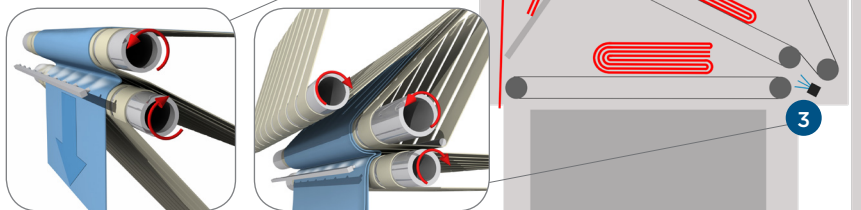

#### 1, 2 OR 4 FEEDING LANES

- Flexible operation depending on the dimensions of the linen being folded.

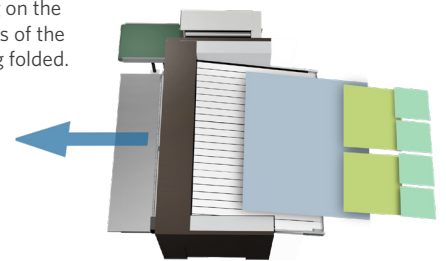

### PRODUCT FEATURES

#### CONTROL

- The touch-screen control features a series of graphic menus to eliminate operator language barriers.
- The control offers 99 program options to fit specific folding requirements and utilizes network communication with feeders and ironers. To facilitate optimum productivity, the control features management capabilities including reporting on item/program counts and overall operating time.
- Simple to use, the control allows operators to easily program and execute the functions of the folder.

#### ACCESSIBILITY / VISIBILITY

- Transparent windows and accessible panels allow for easy maintenance and better control.

#### VERSATILITY

- 1, 2 or 3 primary folds in 1,2 or 4 lanes.
- 1, 2 or 3 cross folds in 1 lane.
- 1, 2 cross folds in 2 lanes.
- General bypass.
- Mechanical bypass.
- Single or double stacker.
- All linen types.

#### OPTIONS

- VISIBILITY & INTERNAL LIGHTING – The FRB folder allows operators to monitor pieces throughout the folding process.
- FITTED TRAY + COUNTER FOR SMALL ITEMS (4 LANES) – An optional accessory fitted at the back of the folder, it works by collecting small items like napkins and pillowcases. It can also be supplied with screens for counting.
- SLIDING TABLE – This option improves the folding of large items.
- ANTISTATIC BAR + IONIZED AIR

# FRB

## FLATWORK FOLDER

### PRODUCT SPECS

Usable Feed Width <i>inch</i>	118 130 138
Feed Height <i>inch</i>	36+
Conveyor Speed <i>ft/min</i>	up to 164
Net Weight <i>lbs</i>	3,858 to 4,409
APB1 Single Stacker Net Weight <i>lbs</i>	606
APB2 Dual Stacker Net Weight <i>lbs</i>	1,212
Crated Weight (including APB1) <i>lbs</i>	5,415
Crated Weight (including APB2) <i>lbs</i>	6,021
Machine Width <i>inch</i>	157.87
Machine Width (w/APB1) <i>inch</i>	199.60
Machine Width (w/APB2) <i>inch</i>	229.92
Machine Depth <i>inch</i>	111.61
Machine Height <i>inch</i>	112.4
Shipping Dimensions (WxDxH) <i>inch</i>	193 x 88.5 x 85
Electrical Power <i>kVA</i>	5.33
Available Voltages / Wire Conductor / Amp	208-240/60/3, 12 x 3 + GND, 20 Amp
Electric	440-480/60/3, 12 x 3 + GND, 15 Amp
Compressed Air Connection <i>inch</i>	1/2 NPT
Compressed Air Flow <i>cfm</i>	35 @ 87-145 PSI

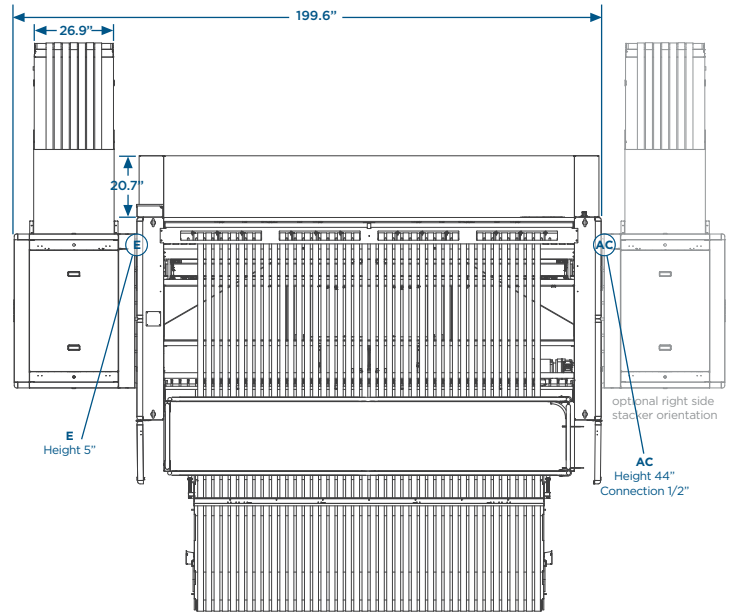

FRB + APB1

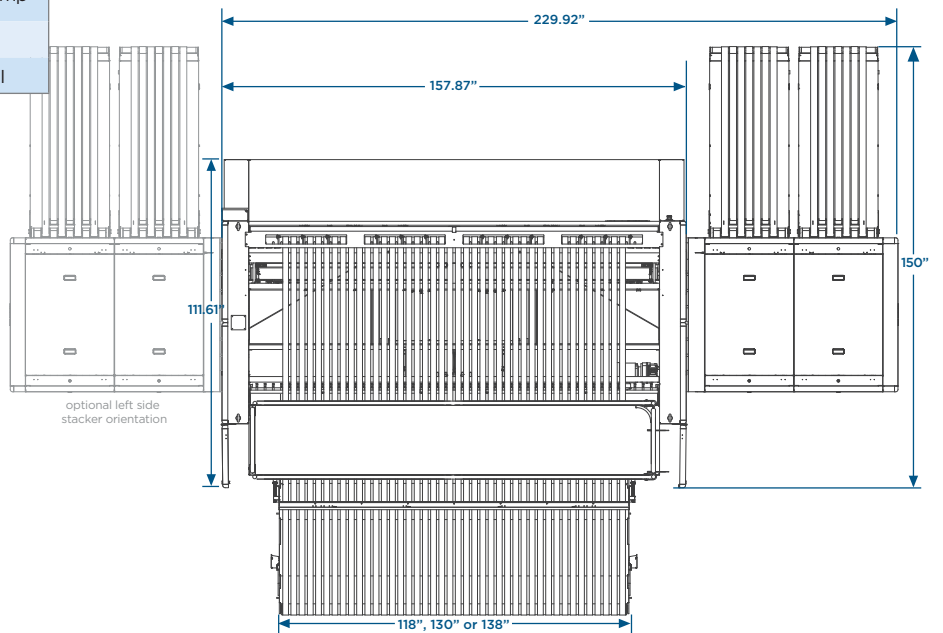

FRB + APB2

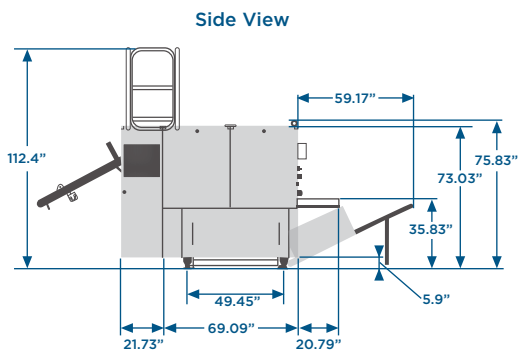

Side View

\* Specifications subject to change without notice or obligation. Contact Girbau Industrial at (800) 256-1073 for dimensions not shown, for clarification or for full system dimensions.