

# DRM+

## COMPACT HIGH PRODUCTION MANUAL FEEDER

The DRM+ is engineered with simplicity, efficiency and quality results in mind. This manual front feeder boosts productivity by up to 40 percent when compared to direct feeding into a flatwork ironer. Simple to operate, the DRM is an economic solution for improving quality and throughput. It processes items of varying types and dimensions.

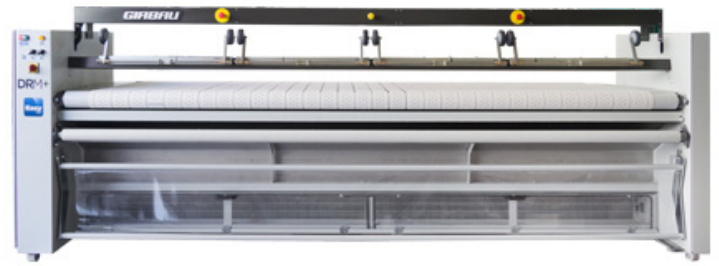

### PRODUCT FEATURES

#### CAPABILITIES

- 1-4 lanes standard, up to 5 lanes optional
- High-quality feeding of small and large items

#### FEEDING TECHNOLOGY

- An inverter drive automatically synchronizes feeder with ironer speed
- Curved plates at the exit of the suction aperture improve spreading and quality
- A set of wheels - with a self-centering system - is arranged on the 4 lanes to support linens and ensure optimal positioning

#### VERSATILE CONTROL

- Menu screens arranged according to function for ease-of-use
- Seamless communication with Girbau Industrial ironers

#### DURABILITY

- Components are independently tested and certified to withstand years of constant use
- Straightforward operation prevents complications in functioning and aids maintenance operations
- 2-year limited parts warranty

#### ACCESSIBILITY & MAINTENANCE

- Suction drawer features easily accessible covers
- Suction aperture features lint-retaining filters to maintain an impeccable laundry environment

#### EASE OF USE

- Ample free space on the feeding conveyor contributes to ergonomic feeding and clear visibility
- Space below feeding conveyor allows room for a laundry cart for improved productivity and working ergonomics

#### ACCESSORIES

- Dedicated lighting over folding table
- Suction table holds linens in place
- Article support tray aids in the feeding of small items
- Movement rails aid in maintenance and cleaning access
- Cart stop prevents laundry carts from bumping against the machine
- Suction collector with side output and collecting bag
- Multiple wheel assembly holds laundry items as they are fed

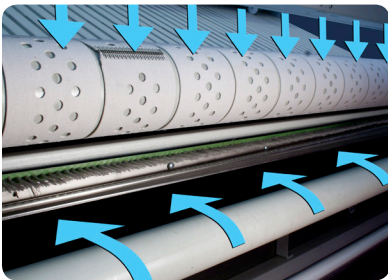

#### SUCTION TABLE

Holds linens & prevents movement for improved productivity.

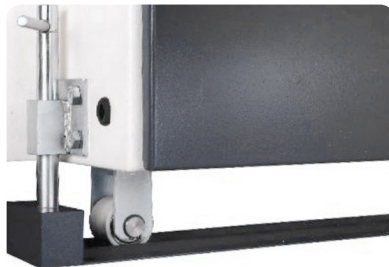

#### MOVEMENT RAILS

This option is essential for aiding access to the feeder and for cleaning and maintenance work, both on the feeder and the flatwork ironer.



#### CART PROTECTION

Steel rail prevents damage from carts.

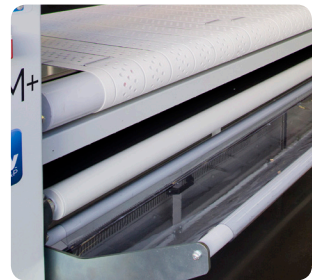

#### ITEM SUPPORT TRAY

Concealable tray aids the insertion of small items.

### PRODUCT SPECS

Usable Feed Width <i>inch</i>	118 130 138
Feed Height <i>inch</i>	59.1
Conveyor Speed <i>ft/min</i>	16 to 164
Net Weight <i>lbs</i>	2425.1
Crated Weight <i>lbs</i>	2755.8
Machine Width <i>inch</i>	159
Machine Depth <i>inch</i>	57
Machine Height <i>inch</i>	62
Shipping Dimensions <i>inch</i> WxDxH	166.9 x 48.8 x 80.7
Electrical Power <i>KVA</i>	2.14
Available Voltages / Wire Conductor / Amp	
Electric	208-240/60/3, 3W+G, 10 Amp
Electric	440-480/60/3, 3W+G, 10 Amp

\* Specifications subject to change without notice or obligation. Contact Girbau Industrial at (800) 256-1073 for dimensions not shown or for clarification.

**SIDE VIEW**

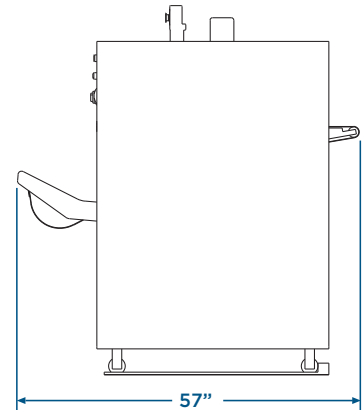

**FRONT VIEW**

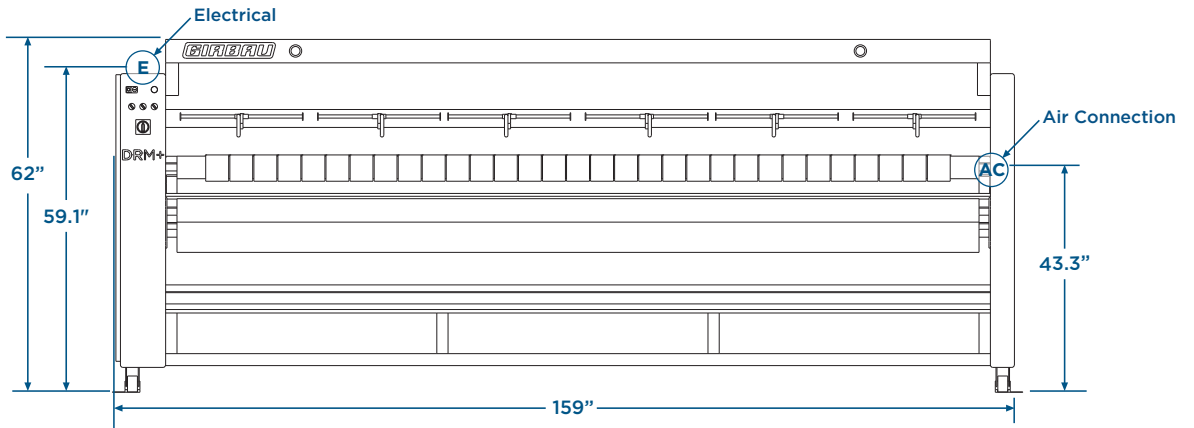

**TOP VIEW**

