

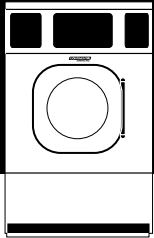

2500 State Road 44 • Oshkosh, WI 54904
 920.231.8222 • FAX 920.231.4666
 www.cgilaundry.com



RMG033

VENDED G-FLEX 33-POUND CAPACITY
 HARD-MOUNT WASHER-EXTRACTOR

Capacity lbs (kg)	33 (15)
Cylinder Diameter inch (mm)	24.4 (620)
Cylinder Depth inch (mm)	16.4 (416)
Cylinder Volume cu ft (dm ³)	4.5 (126)
Net Weight lbs (kg)	525 (238)
Crated Weight lbs (kg)	580 (263)
Machine Width inch (mm)	29.5 (750)
Machine Depth inch (mm)	32.25 (819)
Machine Height inch (mm)	52.9 (1344)
Door Opening inch (mm)	12.9 (327)
Floor to Door inch (mm)	20 (509)
Shipping Dimensions inch (mm) (WxDxH)	30.6 x 37.9 x 58.8 (777 x 962 x 1494)
Washing Speed rpm	47
Spin Speeds rpm	47/100/380/540/635/760
G-force	50/100/140/200
Static Force Transmitted lbs (kg)	721 (327)
Dynamic Force Transmitted lbs (kg)	1387 (629)
Frequency of Dynamic Force Hz	12.7
Available Voltages/Wire Conductor/Amp	208-240/60/1, 2W+G, 10 Amp
Drain Diameter inch (mm)	3 (80)
Water Inlets inch (mm)	2 @ 3/4 (2 @ 19)
Recommended Water Pressure PSI (bar)	30-60 (2-4)
Water Flow gal/min (l/min)	16 (60)
Total Power kW	0.85

* Specifications subject to change without notice or obligation. Call Continental Girbau Inc for dimensions not shown or for clarification.

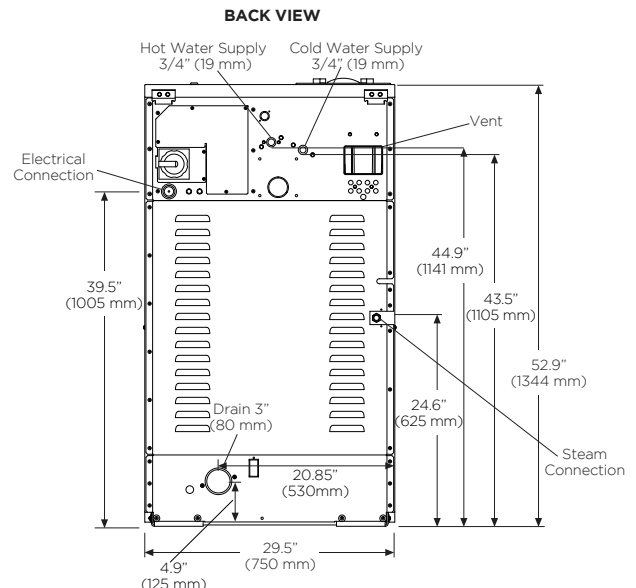
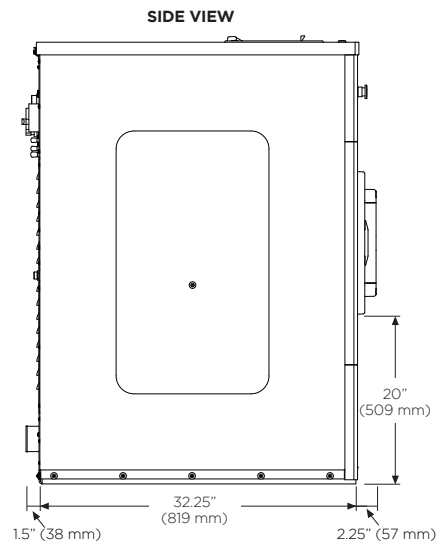
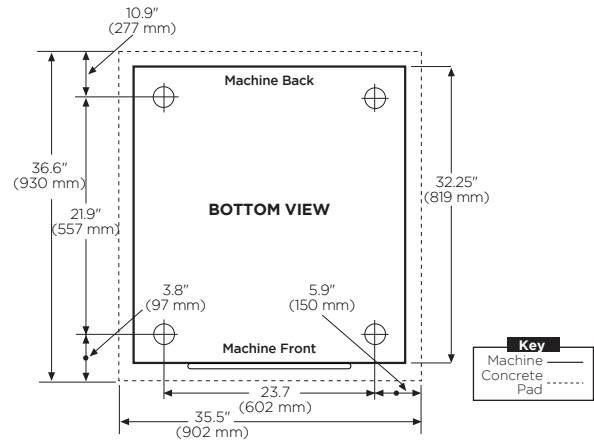

Hard-Mount Installation Requirements

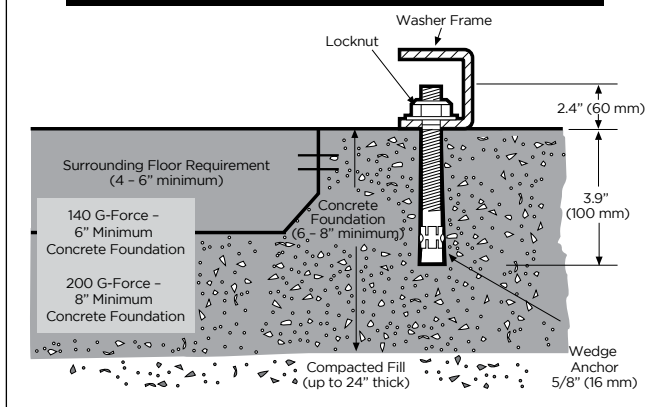



2500 State Road 44 • Oshkosh, WI 54904
 920.231.8222 • FAX 920.231.4666
 www.continentalgirbau.com

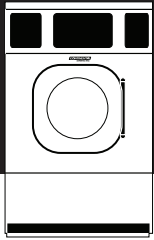

RMG040

VENDED G-FLEX 40-POUND CAPACITY
 HARD-MOUNT WASHER-EXTRACTOR

Capacity lbs (kg)	40 (18.5)
Cylinder Diameter inch (mm)	24.4 (620)
Cylinder Depth inch (mm)	21.6 (549)
Cylinder Volume cu ft (dm ³)	6 (166)
Net Weight lbs (kg)	562 (255)
Crated Weight lbs (kg)	624 (283)
Machine Width inch (mm)	29.5 (750)
Machine Depth inch (mm)	41.8 (1063)
Machine Height inch (mm)	52.9 (1344)
Door Opening inch (mm)	12.9 (327)
Floor to Door inch (mm)	20 (509)
Shipping Dimensions inch (mm) (WxDxH)	30.6 x 43.1 x 58.8 (777 x 1095 x 1494)
Washing Speed rpm	47
Spin Speeds rpm	47/100/380/540/635/760
G-force	50/100/140/200
Static Force Transmitted lbs (kg)	805 (365)
Dynamic Force Transmitted lbs (kg)	1828 (829)
Frequency of Dynamic Force Hz	12.7
Available Voltages/Wire Conductor/Amp	208-240/60/1, 2W+G, 10 Amp
Drain Diameter inch (mm)	3 (76)
Water Inlets inch (mm)	2 @ 3/4 (2 @ 19)
Recommended Water Pressure PSI (bar)	30-60 (2-4)
Water Flow gal/min (l/min)	16 (60)
Total Power kW	0.8

* Specifications subject to change without notice or obligation. Call Continental Girbau Inc for dimensions not shown or for clarification.

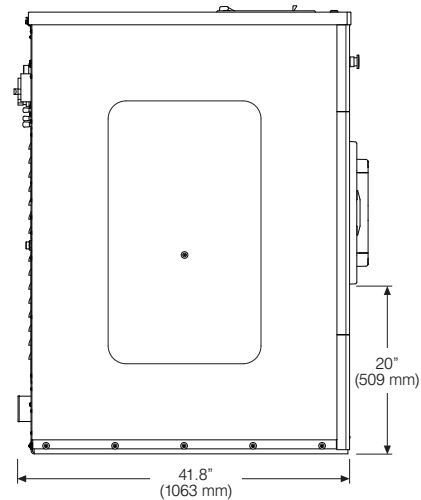
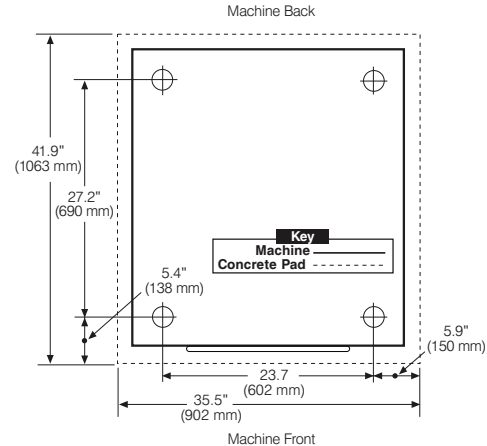

Hard-Mount Installation Requirements

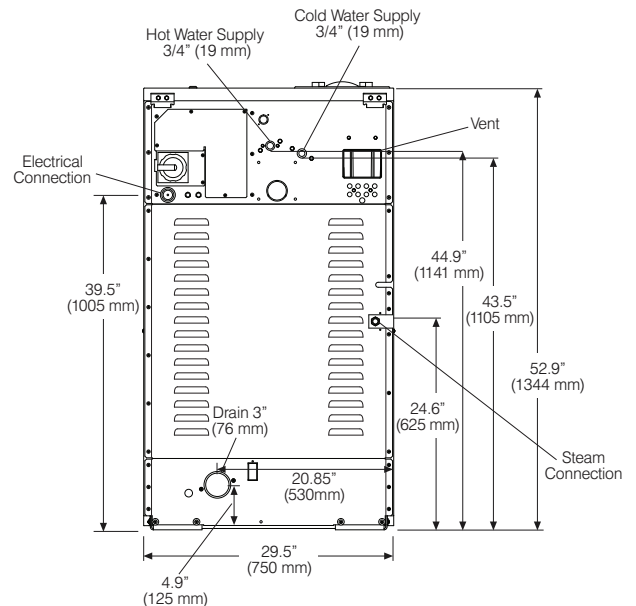
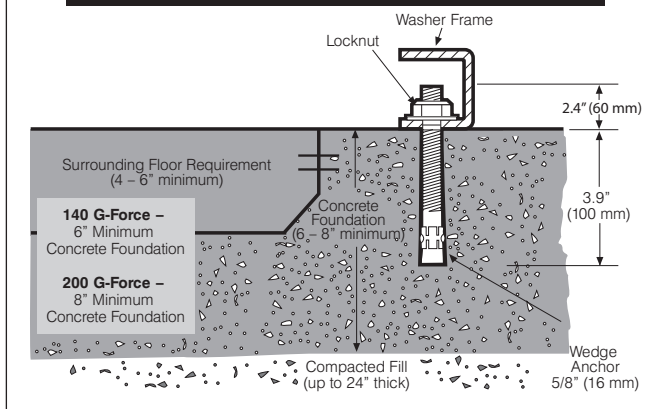



2500 State Road 44 • Oshkosh, WI 54904
 920.231.8222 • FAX 920.231.4666
 www.continentalgirbau.com

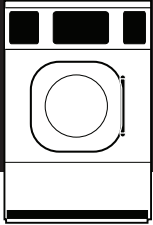

RMG055

VENDED G-FLEX 55-POUND CAPACITY
 HARD-MOUNT WASHER-EXTRACTOR

Capacity lbs (kg)	55 (25)
Cylinder Diameter inch (mm)	27.6 (700)
Cylinder Depth inch (mm)	23.1 (586)
Cylinder Volume cu ft (dm ³)	8 (226)
Net Weight lbs (kg)	741 (336)
Crated Weight lbs (kg)	807 (366)
Machine Width inch (mm)	34.3 (870)
Machine Depth inch (mm)	44.8 (1139)
Machine Height inch (mm)	56.1 (1424)
Door Opening inch (mm)	16.8 (426)
Floor to Door inch (mm)	19.7 (500)
Shipping Dimensions inch (mm) (WxDxH)	35.3 x 46.1 x 61.6 (897 x 1170 x 1565)
Washing Speed rpm	45
Spin Speeds rpm	45/100/360/505/600/715
G-force	50/100/140/200
Static Force Transmitted lbs (kg)	1052 (477)
Dynamic Force Transmitted lbs (kg)	2487 (1128)
Frequency of Dynamic Force Hz	11.9
Available Voltages/Wire Conductor/Amp	208-240/60/1, 2W+G, 10 Amp
Drain Diameter inch (mm)	3 (76)
Water Inlets inch (mm)	2 @ 3/4 (2 @ 19)
Recommended Water Pressure PSI (bar)	30-60 (2-4)
Water Flow gal/min (l/min)	16 (60)
Total Power kW	1.05

* Specifications subject to change without notice or obligation. Call Continental Girbau Inc for dimensions not shown or for clarification.

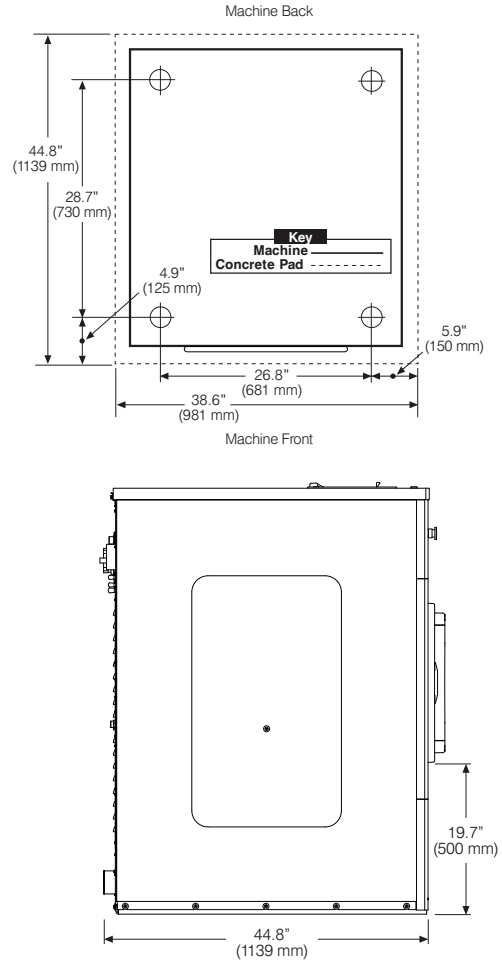

Hard-Mount Installation Requirements

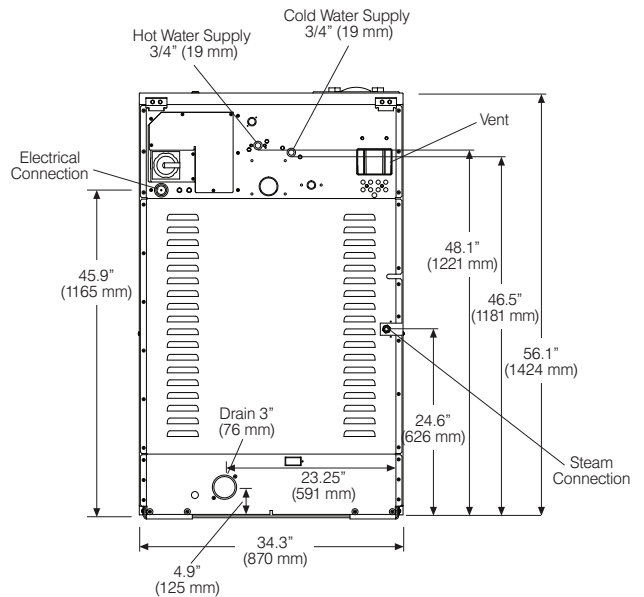
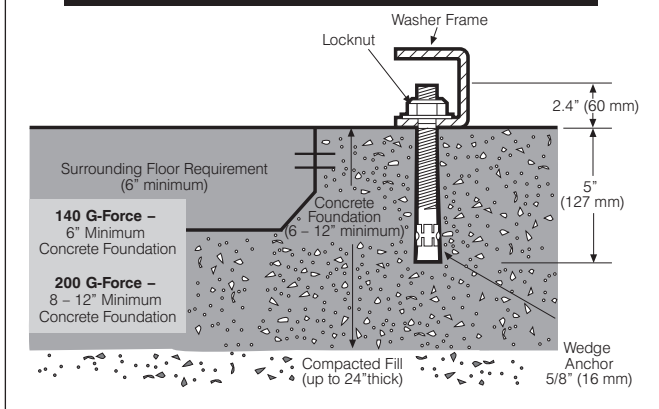



2500 State Road 44 • Oshkosh, WI 54904
 920.231.8222 • FAX 920.231.4666
 www.continentalgirbau.com

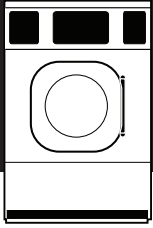

RMG070

VENDED G-FLEX 70-POUND CAPACITY
 HARD-MOUNT WASHER-EXTRACTOR

Capacity lbs (kg)	70 (30.5)
Cylinder Diameter inch (mm)	30.1 (765)
Cylinder Depth inch (mm)	23.5 (596)
Cylinder Volume cu ft (dm ³)	9.7 (274)
Net Weight lbs (kg)	899 (408)
Crated Weight lbs (kg)	957 (434)
Machine Width inch (mm)	34.3 (870)
Machine Depth inch (mm)	45 (1143)
Machine Height inch (mm)	57.7 (1466)
Door Opening inch (mm)	16.7 (424)
Floor to Door inch (mm)	21.4 (544)
Shipping Dimensions inch (mm) (WxDxH)	35.3 x 48.2 x 64.1 (897 x 1225 x 1627)
Washing Speed rpm	40
Spin Speeds rpm	40/86/342/485/570/685
G-force	50/100/140/200
Static Force Transmitted lbs (kg)	1208 (548)
Dynamic Force Transmitted lbs (kg)	3086 (1400)
Frequency of Dynamic Force Hz	11.4
Available Voltages/Wire Conductor/Amp	208-240/60/1, 2W+G, 15 Amp 208-240/60/3, 3W+G, 15 Amp
Drain Diameter inch (mm)	3 (76)
Water Inlets inch (mm)	2 @ 3/4 (2 @ 19)
Recommended Water Pressure PSI (bar)	30-60 (2-4)
Water Flow gal/min (l/min)	16 (60)
Total Power kW	1.3

* Specifications subject to change without notice or obligation. Call Continental Girbau Inc for dimensions not shown or for clarification.

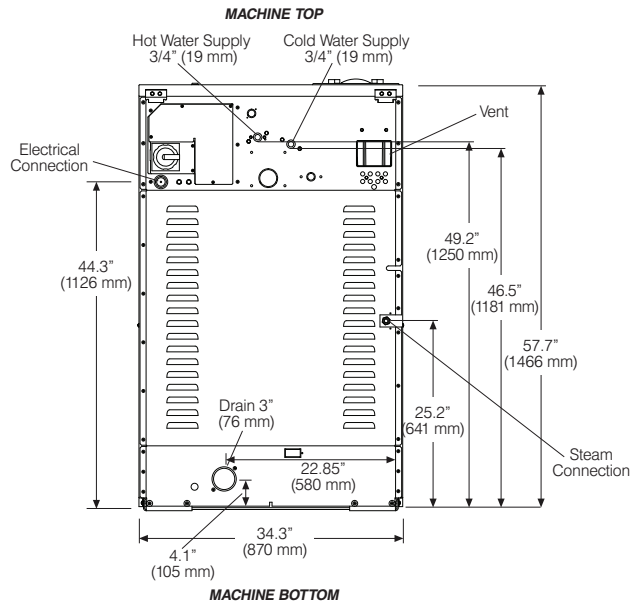
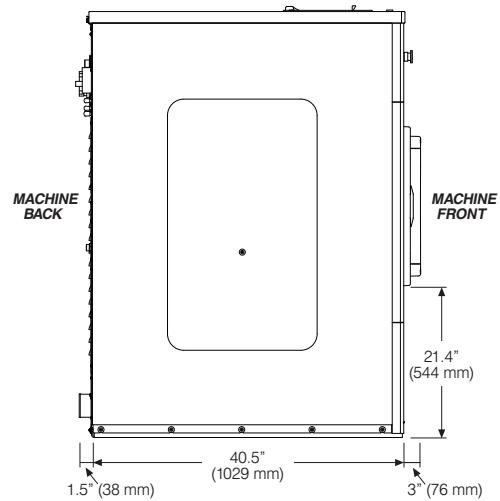
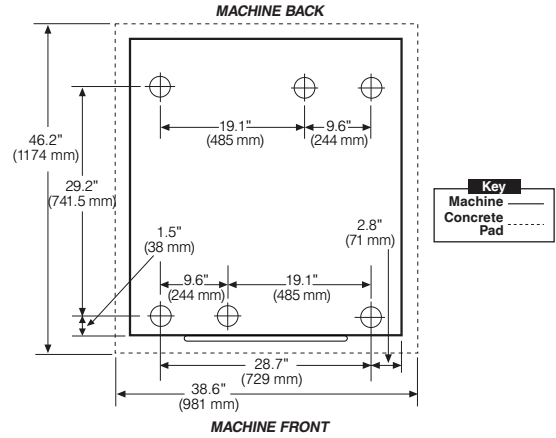

Hard-Mount Installation Requirements

